

FUNDAMENTALS OF GD&T

Learn and Understand the Correct Application of GD&T

- Save money at design stage
- Enable global sourcing
- Reduce drawing errors
- Increase productivity
- Increase part tolerances
- Assure that mating parts will assemble
- Eliminate scrap
- Improve inspection accuracy

Course Objective

Combined with a basic understanding of mechanical drawings, this course will teach students the terms, rules, symbols and concepts of GD&T as prescribed in the ASME Y14.5M-1994 Standard.

Course Description

Students will develop a basic understanding of geometric symbols, including each symbol's requirements, tolerance zones, and limitations. The class includes a comparison of GD&T to coordinate tolerancing; an explanation of tolerance zones: Rules #1 and #2; form and orientation controls; tolerance of position; runout and profile controls. Throughout the class, students hone their newly acquired skills with over 300 practice problems. This complete course in GD&T fundamentals is the most thorough and comprehensive training on the market.

Who Should Attend

This class is a valuable tool for individuals who create or interpret engineering drawings: product and gage designers; process, product, and manufacturing engineers; supplier quality engineers; CMM operators; buyers/purchasers; checkers; inspectors; technicians; and sales engineers.

Prerequisites

- Students should have basic print reading skills.

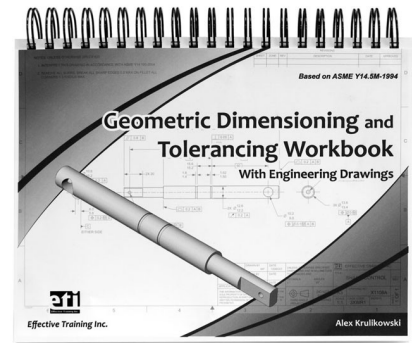

Class Materials

- A copy of *The Fundamentals of GD&T*, by Alex Krulikowski
- *A GD&T Ultimate Pocket Guide*
- *A Fundamentals of GD&T Exercise Workbook*
- Class handouts
- An official certificate of completion

Class Structure

- On-site, instructor-led
- 2 Days of instruction
- Minimum 10 students per class



Course Topics—Fundamentals of GD&T

Introduction

- Engineering drawings
- GD&T/coordinate dimensioning comparison
- Eight key GD&T terms

Terminology

- GD&T modifiers and symbols
- Rule #1 and Rule #2
- Basic dimensions, virtual condition, bonus tolerance

Form Controls

- Flatness, straightness, circularity and cylindricity

Datums

- The datum system (planar datums)
- Interpreting datum targets
- Feature of size datum specifications (RFS)
- Feature of size datum specifications (MMC)
- Parallelism

Orientation Controls

- Perpendicularity
- Angularity

Tolerance of Position Controls

- Definitions, conventions, advantages, basic theories
- RFS and MMC tolerance of position applications
- Tolerance of position special applications
- Tolerance of position special applications
- Calculating distances on parts dimensioned w/tolerance of position
- Fixed and floating fastener formulas

Concentricity/Symmetry Controls

- Concentricity
- Symmetry

Runout Controls

- Circular runout
- Total runout

Profile Controls

- Profile tolerancing
- Profile of a surface
- Profile of a line

Final Exam

- Closing comments

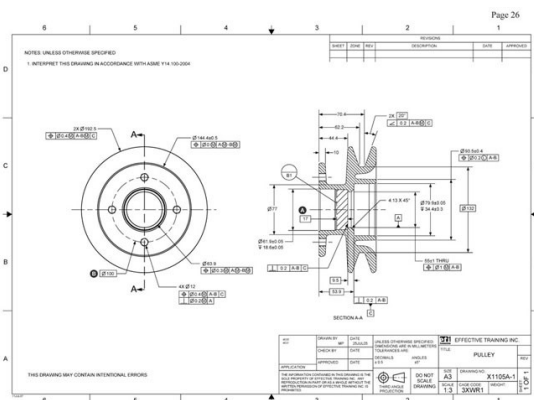

Course Developer: Alex Krulikowski, President of Effective Training Inc. (ETI)

The *Fundamentals of GD&T* training materials were developed by Alex Krulikowski, the noted GD&T educator, author and consultant. Alex has more than 30 years of industrial experience putting GD&T to practical use. He is a member of the ASME Y14..5 Committee on Dimensioning and Tolerancing and served as chairman of the Y14.41 Committee on Solid Model Dimensioning for six years. Alex is considered an recognized expert on teaching GD&T's application as prescribed by the standards. More than 60,000 students have learned GD&T using his methods.